

**DETALLE PANEL (T2) - VENTANAS (V3)**

Esc. 1:50

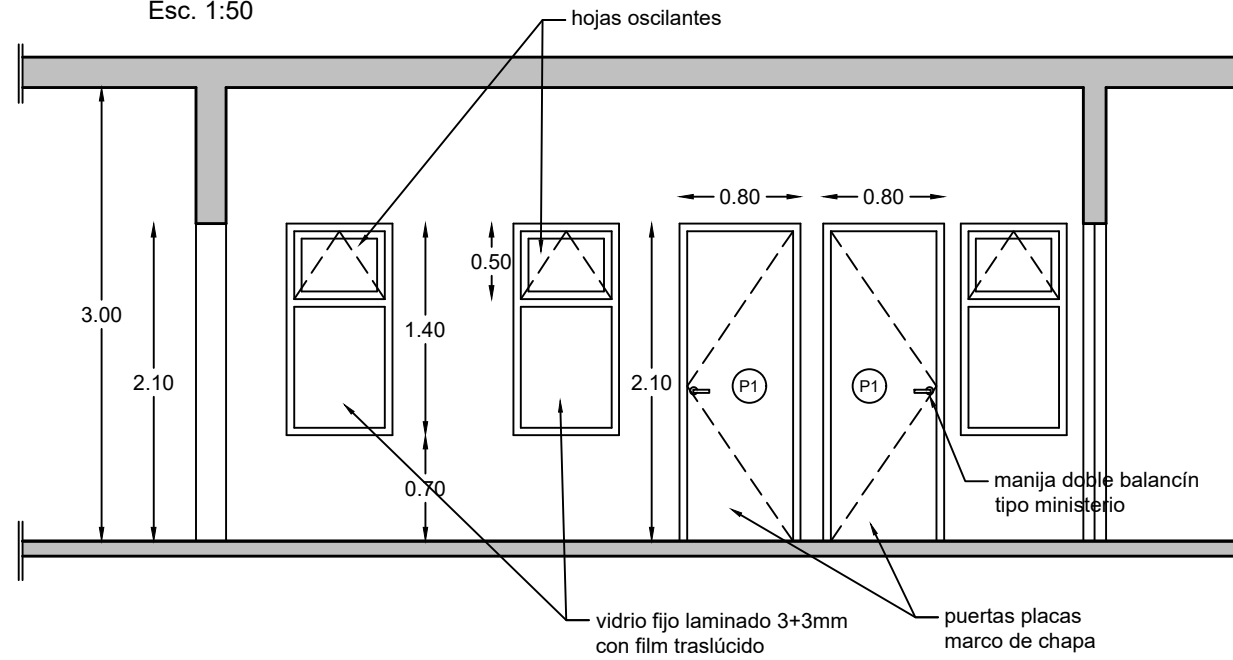

**DETALLE VENTANAS (V1)**

Esc. 1:50

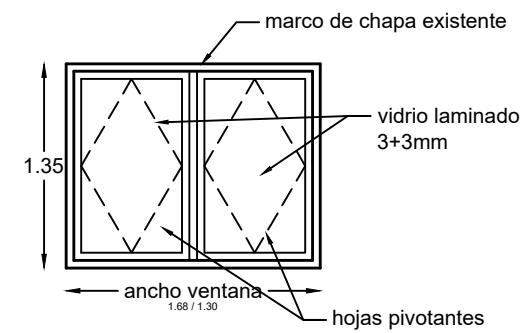

**DETALLE VENTANA (V2)**

Esc. 1:50

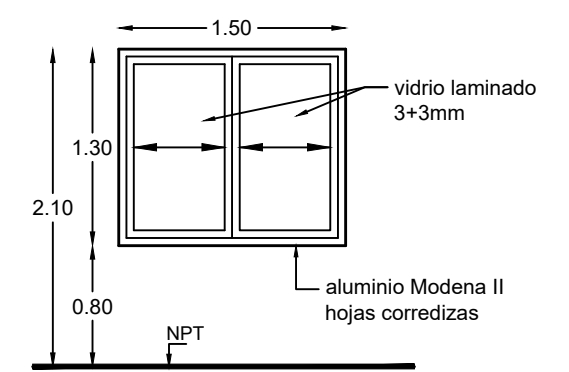

**DETALLE TECHO DE PATIO**

Esc. 1:50

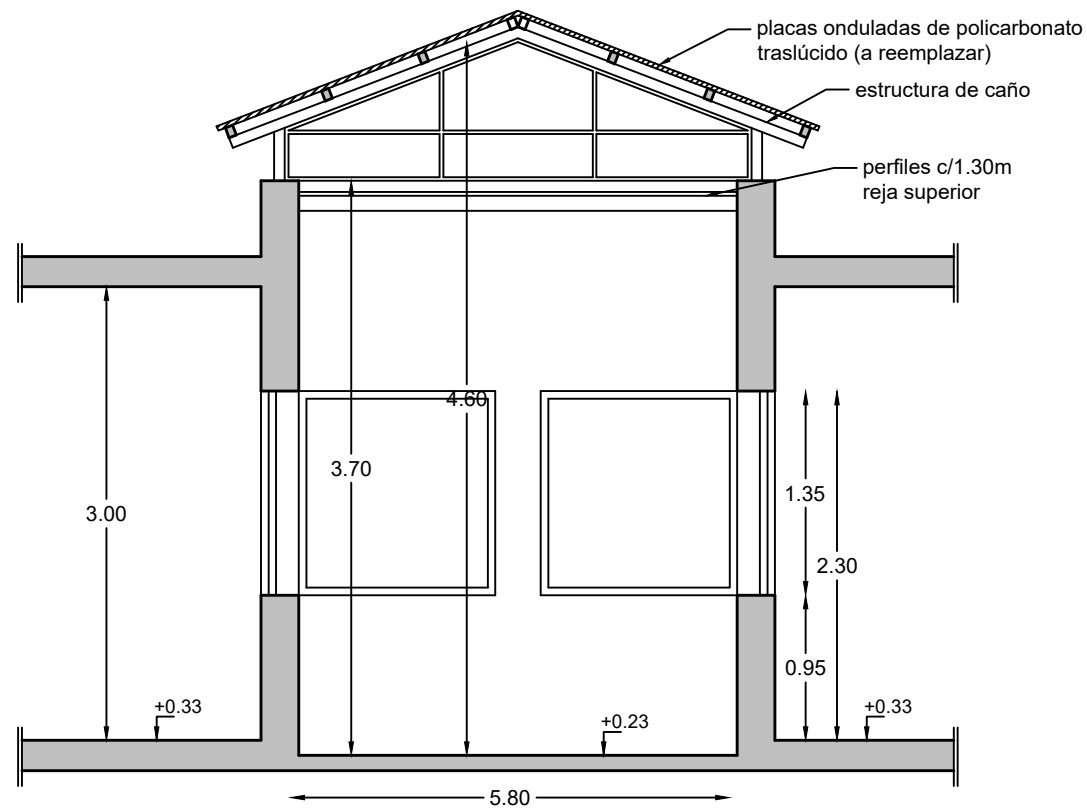

**DETALLE PANELES (T1 y T2)**

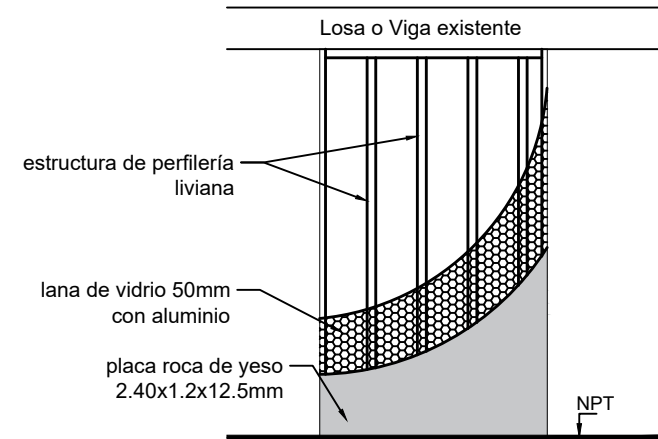

**DETALLE PUERTAS (Pe2)**

Esc. 1:50

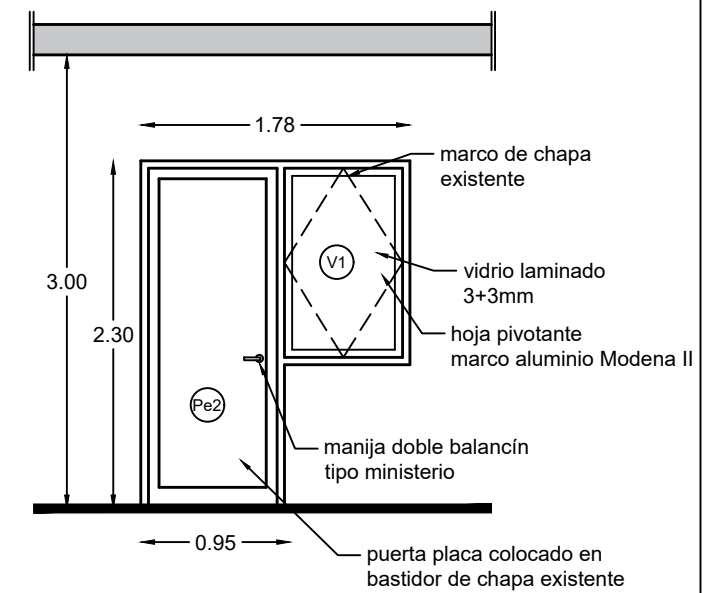

**PODER JUDICIAL DE SAN JUAN**  
DEPARTAMENTO DE SERVICIOS GENERALES

**PLANO N°2**

PROYECTO: REFORMA CAVIG

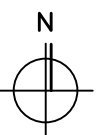

PLANO: CARPINTERÍA - DETALLES

Revisión N° 02

23/06/2021

ESC.: variable